

ZeeWeed* 500D cassette for water & tertiary

DIMENSIONI CASSETTE			
Modello	Width (A) mm (in)	Length (B) mm (in)	Height (C) mm (in)
68M	1,745 (68.7)	2,136 (84.1)	2,561 (100.8)
20M	738 (29.1)	1,744 (68.7)	2,512 (98.9)
20Ms			2,149 (84.6)

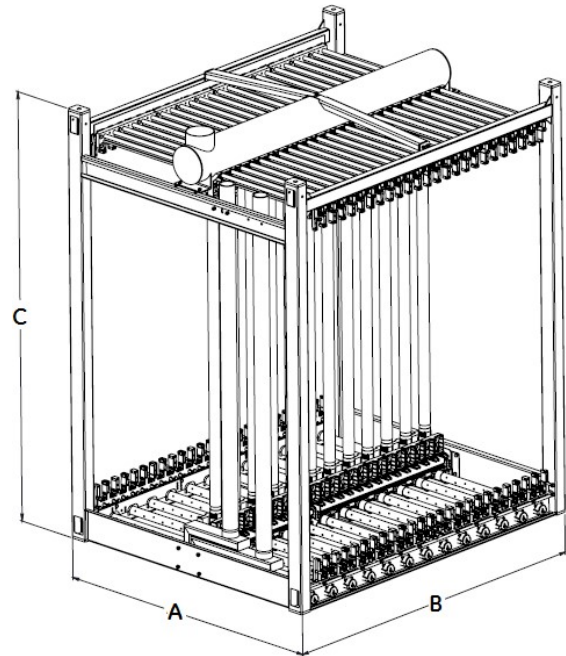

Figure 1: Example Drawing of Cassette

CONNESSIONI e PESI DELLE CASSETTE						
Modello	Max. # of ZW Modules	Min. # of ZW Modules	Permeate Connection	Air Connection	Max. Shipping Weight* kg (lb)	Lifting Weight ** kg (lb)
68M D	68	34	1 x 8" horz. Pipe	1 x 3" FNPT	2,489 (5,488)	2,751 – 4,467 (6,066 – 9,850)
20M D	20	10	2 x 4" FNPT	1 x 3" FNPT	920 (2,029)	961 – 1,555 (2,029 – 3,428)
20M Ds	20	10			892 (1,966)	930-1,415 (2,051-3,121)

* Crated with maximum number of modules

** Varies with number of modules and solids accumulation